

8

7

6

5

4

3

2

1

**NOTES (UNLESS OTHERWISE SPECIFIED):**

1. ALL COMPONENTS AND MATERIALS OF THIS ASSEMBLY OR PART MUST BE CERTIFIABLY ROHS COMPLIANT.
2. 3D DATA BASE SHALL BE USED IN CORRELATION WITH THIS DRAWING FOR FEATURES NOT DIMENSIONED ON FACE OF THIS DRAWING.
3. 3D MODEL (STEP) FILE AVAILABLE UPON REQUEST.
4. SPECIFICATIONS APPROVED PER CX4000B CONTROLLER OR NMLASER ELECTRICAL SPECIFICATIONS.
5. LSTXYW8 BACKWARD COMPATIBLE WITH HIGHER PERFORMANCE.

REVISIONS			
REV.	DESCRIPTION	DATE	APPROVED
A	INITIAL RELEASE	01/17/20024	M.K.

**LST800-20MM SPECIFICATIONS**

<b>OPTICAL SPECS.</b>	
Aperture Size	20 mm
Typical Beam Diameter	6-18 mm
Maximum Power Handling	300 W with Chiller Plate
Dielectric Optics	1064 nm (-1), 532 nm (-2), 355 nm (-3), 266 nm (-4),
Metal Optics	CO2 (-C2), IR (-IR), STD (AL)
Damage Threshold	15 J/cm <sup>2</sup> @ 10ns (Dielectric Optic)

<b>ELECTRICAL SPECS.</b>	
Power Supply	24 VDC, 3 AMP RATING

Optimum Electrical Drive Circuit CX4000B Recommended	Boost Open = 24V for 55 ms Boost Ramp-up = 15 ms Hold Open = 7 V Delay = 16 ms Brake = 24V for 10 ms
---	--

Winding Resistance	8 Ohms
Winding Inductance	25 mH
Position Sensors	Micro-switch PN 311SM706-T
Cable type, length, termination	6 wires, 22g, 6ft, flying leads

<b>PERFORMANCE SPECS.</b>	
Open Delay Time	10 ms
Open Rise Time	60 ms
Open Total Time	70 ms
Close Delay Time	10 ms
Close Fall Time	20 ms
Close Total Time	70 ms
Min. FWHM Exposure	200 ms
Max. Repetition Rate	2 Hz

<b>THERMAL SPECS.</b>	
Power Dissipation Holding Open	6 W
Power Dissipation Cycling	10 W @ 2 Hz
Mounting Surface	Datum A OR DATUM B

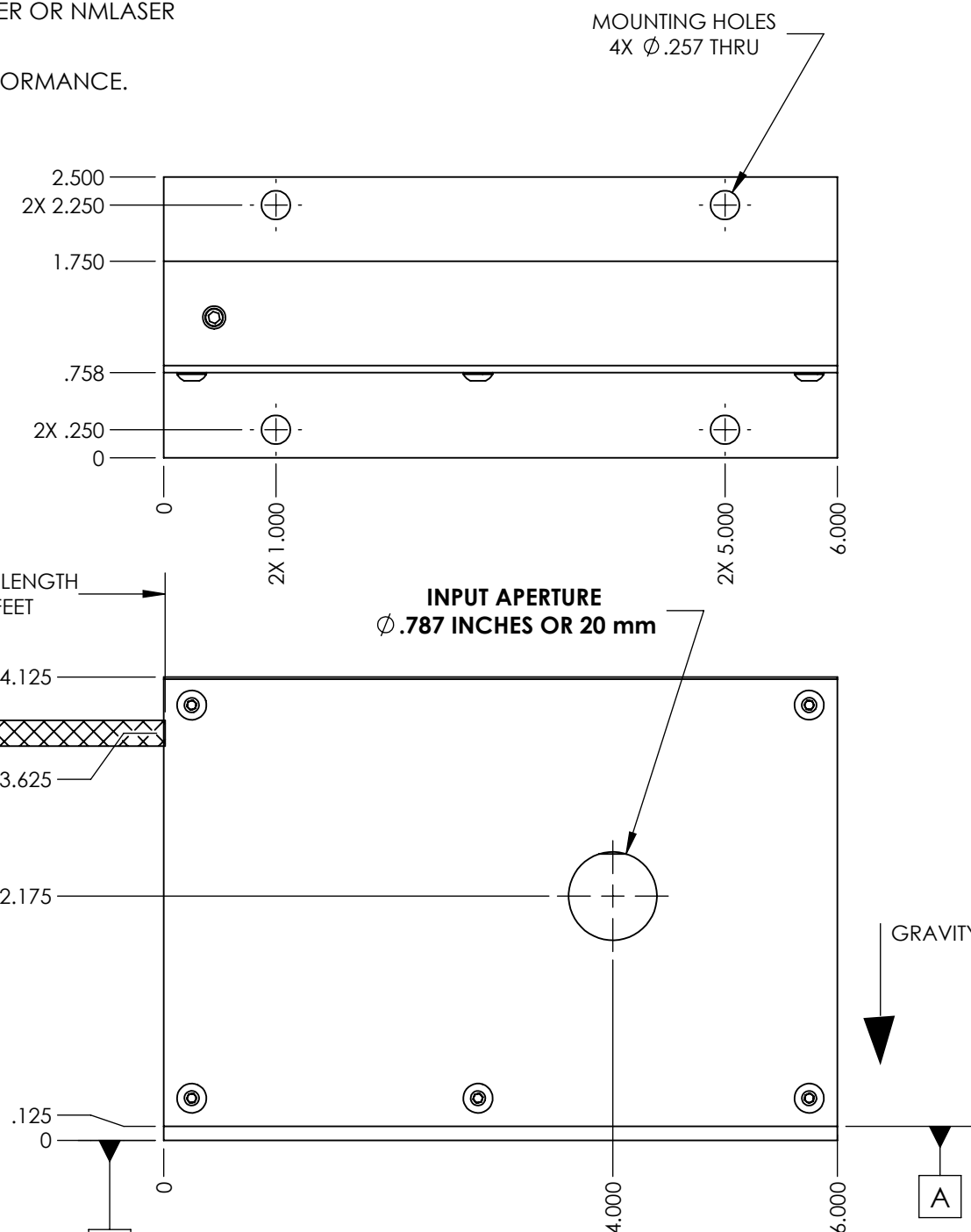

**B** REMOVABLE BASE PLATE  
STANDARD MOUNTING ORIENTATION WITH RESPECT TO GRAVITY:  
SPECIFY OTHERWISE.

WIRE	COLOR	FUNCTION
1	WHITE	POWER WINDING (+)
2	BLACK	POWER WINDING (-)
3/4	RED/ORANGE PAIR	READS CONTINUITY WHEN SHUTTER OPEN
5/6	BLUE/GREEN PAIR	READS CONTINUITY WHEN SHUTTER CLOSED

**PROPRIETARY AND CONFIDENTIAL**  
THE DESIGN INFORMATION CONTAINED HEREIN IS THE SOLE PROPERTY OF NM LASER PRODUCTS, INC. THE DISCLOSURE OF THIS INFORMATION DOES NOT CONSTITUTE THE RELEASE OF THE PROPRIETARY RIGHTS THEREOF, BUT IS TO BE USED FOR INFORMATION PURPOSES ONLY WHEN NECESSARY. PERMISSION TO REPRODUCE THIS INFORMATION OF THE PRODUCT DESCRIBED HEREIN MUST BE OBTAINED IN WRITING FROM NM LASER PRODUCTS, INC.

DIMENSIONS ARE IN INCHES TOLERANCES: ANGULAR: ±1° ONE DECIMAL: X.X ±.1 TWO DECIMAL: X.XX ±.015 THREE DECIMAL: X.XXX ±.005	NAME	DATE	 TITLE: <b>SHUTTER, 20 mm APERTURE, LST800</b>	
	DRAWN	M.K.		1/17/24
	CHECKED	M.K.		1/17/24
	ENG APPR.	M.K.		1/17/24
MFG APPR.			SIZE <b>B</b>	
Q.A.			DWG. NO. <b>LST800-20mm</b>	
3RD ANGLE PROJECTION			REV <b>A</b>	
DO NOT SCALE DRAWING			SCALE: 2:3	
			SHEET 1 OF 2	

8

7

6

5

4

3

2

1

# NM Laser Products LST800 safety shutter

## Beam Properties, Alignment, and Polarization

Each shutter has an optical rating that must be observed to avoid optical and mechanical damage. Carefully consider rated wavelength (for dielectric mirrors) or range of wavelengths (for metal mirrors), CW maximum power, peak energy density (fluence), recommended beam diameter, polarization vector if applicable, and beam alignment. Shutters are designed for typical beams that use 50-80% of the aperture diameter. If a small beam is to be used in a larger aperture, and/or the fluence or CW power is high, our sales/engineering team can recommend safe thresholds to prevent optical damage from operation outside the recommended ranges.

Use suffix -1 for 1064 nm, -2 for 532 nm, -3 for 355 nm, -4 for 266 nm, and -12 for 532 + 1064 nm harmonic mirror (lower damage threshold). Use the -C2 suffix for CO2 lasers. Choose the -IR suffix for CO2 and IR use, starting at about 700 nm.

Beams need to be aligned and entering the "input aperture" to ensure the dumped energy is reflected to the proper location. Dielectric optics require good alignment practices to provide the highest reflectivity and damage thresholds. The entering beam should be orthogonal to the input face within about 3 degrees. The laser beam should NEVER be directed into the output aperture! If the optics in your shutter are polarized, please ensure that the laser beam polarization is properly aligned with the polarization vector label on input aperture side.

## Safe Mounting and Thermal Management

Shutters must be rigidly mounted to keep the beam aligned inside the aperture. The heat generated inside the shutter during normal operation must be handled through proper heatsink mounting. In general, the shutter mount must be made of high thermal conductivity material, there must be a large cross section of material from the shutter base (or body for body mounted models) all the way to the "infinitely" large heatsink, and the mount or hardware in proximity must not be ferromagnetic. This usually leads to using aluminum for the heatsink/mount.

Shutter performance will be degraded if temperatures exceed 50 °C, and most shutters will fail to open at temperatures above 80 °C, signaling a thermal overload. Exceeding 110 °C for any amount of time will cause irreversible damage. In situations where you want to isolate the system from shock and vibrations, consider a water chiller plate, or in special cases, the possibility of air cooling. This allows the shutter to be mechanically "suspended" while still receiving necessary cooling. Air cooling is usually not recommended but may be achieved through careful design considerations.

## Electrical Design and Considerations

The power circuit must be properly calibrated to ensure the shutter will perform as intended by the manufacturer. If the boost signal is too short the shutter will not fully open. If the boost is too long, the fast acceleration of the flexure and resulting velocity may cause a recoil instead of a latch to the open state. Of course, a very long boost period will eventually settle, regardless of recoil, but the recoil may be enough to allow light leakage through the aperture. The ideal circuit switches from boost level (typically 24-28 V) to hold level (typically around 10 V) when the flexure arm is about 75% through its travel distance. There should be no significant dropout in voltage between boost and hold, unless properly accounted for. Our controllers are precisely calibrated for each shutter model to ensure optimum performance, peak efficiency, and to maximize lifetime.

TITLE:		
GUIDELINES		
SIZE	DWG. NO.	REV
	BLST800-20mmA	A